

The enclosed Cloud County Sanitary Code has been officially adopted by the Cloud County Board of Commissioners.

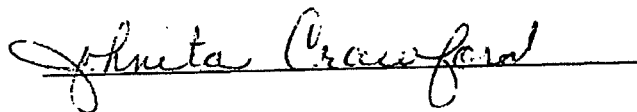

Signature

Chairman, Board of Commissioners

02-28-11

Date

Return to:

KDHE-Watershed Management Section

1000 SW Jackson, Suite 420

Topeka, KS 66612-1367

RESOLUTION NO. 11 - 10

A RESOLUTION AMENDING THE  
CLOUD COUNTY, KANSAS ENVIRONMENTAL  
SANITARY CODE

WHEREAS, on February 28, 2011, the Cloud County Commission of Cloud County, Kansas, has held a public hearing pursuant to Notice of their intention to consider adopting the revised Environmental Sanitary Code of Cloud County, Kansas, dated March 4, 2004, as amended, and

WHEREAS, the Board of County Commissioners of Cloud County, Kansas, has now received and considered said revision and found the revision to be desirable and necessary for the protection of the health and welfare of the public in Cloud County, Kansas. Said Environmental Sanitary Code shall be available for inspection at the Cloud County Courthouse, Concordia, Kansas.

NOW, THEREFORE, BE IT RESOLVED by the Board of County Commissioners of Cloud County, Kansas, that the proposed revision for the Environmental Sanitary Code of Cloud County, Kansas, a copy of which revision is attached hereto, marked Exhibit A and incorporated herein as though full set forth herein, be and is hereby adopted.

Adopted this 28<sup>th</sup> day of February, 2011.

BOARD OF COUNTY COMMISSIONERS  
CLOUD COUNTY, KANSAS

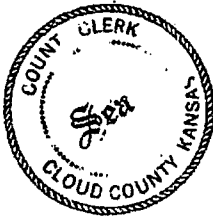

Shirley Crawford

Ray Casper

ATTEST:

Cathy Davis  
Cathy Davis, Deputy  
Linda Bogart, County Clerk

Vote: Yea X Nay

**CLOUD COUNTY  
SANITARY CODE**

**CLOUD COUNTY, KS**

**JANUARY 2011**

APPROVED

JAN 35 2011

Kansas Department of  
Health and Environment

# Cloud County Sanitary Code

## Table of Contents

### Chapter 1 - Administrative Procedures

Section 1-1.0 Authorization and Policy.....	Page 2
Section 1-2.0 Definition .....	Page 3
Section 1-3.0 Administrative Powers and Procedures .....	Page 4

### Chapter 2 - On-site Wastewater Management

Section 2-1.0 Purpose and Intent.....	Page 7
Section 2-2.0 Applicability.....	Page 7
Section 2-3.0 Definitions .....	Page 7
Section 2-4.0 Prohibited Practices .....	Page 8
Section 2-5.0 Requirements for Private Wastewater Disposal Systems .....	Page 9
Section 2-6.0 Minimum Standards for Soil Topography and Geology .....	Page 11
Section 2-7.0 Requirements for Wastewater Ponds/Lagoons .....	Page 11
Section 2-8.0 Requirements for Sanitary Privies .....	Page 11
Section 2-9.0 Requirements for Subdivision Development .....	Page 11

### Chapter 3 - Private Water Supplies

Section 3-1.0 Purpose and Intent .....	Page 12
Section 3-2.0 Applicability .....	Page 12
Section 3-3.0 Definitions .....	Page 12
Section 3-4.0 Requirements for Private Domestic Water Supplies .....	Page 13
Section 3-5.0 Minimum Standards for Groundwater Supplies .....	Page 13
Section 3-6.0 Requirements for Subdivision Development .....	Page 13

<b>Table 1 – Minimum Separation Distance Between Private Domestic Water Supply Wells and Sources of Pollution.....</b>	<b>Page 14</b>
------------------------------------------------------------------------------------------------------------------------	----------------

<b>Appendix A – Wastewater Lagoon Systems.....</b>	<b>Page 15</b>
----------------------------------------------------	----------------

APPROVED

JAN 30 2011

Kansas Department of  
Health and Environment

**SANITARY CODE**  
**CLOUD COUNTY, KANSAS**  
**CHAPTER 1**  
**ADMINISTRATIVE PROCEDURES**

**SECTION 1-1.0 AUTHORIZATION AND POLICY**

1-1.1 LEGAL AUTHORITY. This code is adopted under the authority granted to the Board of County Commissioners by K .S.A. 19-3701 et.seq. as amended.

1-1.2 DECLARATION OF FINDING AND POLICY. The Commissioners find that reasonable control over the sanitary conditions in Cloud County is necessary to adequately enforce the sanitary laws of the State of Kansas. A sanitary code established standards to eliminate and/or prevent conditions that are hazardous to public safety in an economical and planned way.

For these reasons and objectives, it will be the policy of the Cloud County Commissioners to adopt, and amend when necessary, a sanitary code for the regulation of sanitary practices that affect the public health and safety.

1-1.3 PURPOSE. The purpose and intent of this chapter is to prescribe the administrative procedures to be followed in administering this sanitary code or any amendments thereto.

1-1.4 TITLE. This code shall be known and referred to as the Cloud County Sanitary Code.

1-1.5 APPLICABILITY. The procedures prescribed in the chapter shall be followed in administering the code and any amendments thereto.

1-1.6 EFFECTIVE DATE. This code shall become effective June 9, 1997 and amended January 5, 2011.

APPROVED

JAN 05 2011

Kansas Department of  
Health and Environment

## SECTION 1-2.0 DEFINITIONS

The following words terms and phrases appear in more that one chapter of this code and thus have general application and usage. Words, terms and phrases appropriate or applicable to specific chapters within this code may be found in that particular chapter.

1-2.1 ADMINISTRATIVE AGENCY means the entity authorized to administer and implement the provisions of this code, and to hear appeals made by the hearing officer. The Administrative Agency for Cloud County is designated as the Board of County Commissioners of Cloud County, Kansas or the duly Authorized Representative of the Board of County Commissioners of Cloud County, Kansas .

1-2.2 ADMINISTRATIVE RULES means those rules contained in chapter one of this sanitary code that prescribe general procedures to be followed in the administration if the sanitary code adopted by the county.

1-2.3 AUTHORIZED REPRESENTATIVE means any person who is designated by the Administrative Agency to administer this code.

1-2.4 BOARD OF COUNTY COMMISSIONERS means the Board of County Commissioners of Cloud County, Kansas.

1-2.5 BOARD OF HEALTH means the Cloud County Board of Health and is also known as the Cloud County Board of Commissioners.

1-2.6 HEARING OFFICER means an individual, appointed by the Administrative Agency, to hear appeals from the decisions made by the Authorized Representative relating to the enforcement and administration of the code.

1-2.7 KDHE means the Kansas Department of Health and Environment.

1-2.8 PERSON means an individual, corporation, partnership, association, state, or political subdivision thereof; federal, state agency, municipality, commission, or interstate body of other legal entity recognized by the law as the subject of rights and duties.

1-2.9 PREMISE means any lot, parcel, or tract of land and all buildings, structures, or facilities located thereon.

APPROVED

JAN 05 2011

Kansas Department of  
Health and Environment

## SECTION 1-3.0 ADMINISTRATIVE POWERS AND PROCEDURES

1-3.1 RIGHT OF ENTRY. After a person attains a permit of this code, the Authorized Representative shall have the power and authority to inspect the premises for compliance with the Cloud County Sanitary Code for the project for which the permit was issued as granted under K.S.A. 65-159. Right of entry is also authorized to the Authorized Representative if a written complaint is filed with the Authorized Representative and written notice is provided to the landowner prior to the inspection.

### 1-3.2 PERMIT AND LICENSE

1-3.2.1 APPLICATION FOR PERMITS AND LICENSES. Every person by this sanitary code to obtain a permit or license for new construction shall make application for such permit or license to the Cloud County Clerk or the Authorized Representative.

1-3.2.2 ISSUANCE OF PERMIT OR LICENSE. After receipt of an application for new construction as required by this code, the Authorized Representative shall begin such investigation as deemed necessary to determine whether the permit or license should be issued or denied, and shall issue or deny the permit or license within 14 days or such receipt. If the permit or license is denied, the Authorized Representative shall send the applicant a written notice; state the reasons for the rejection, and procedure to appeal.

1-3.2.3 PERMIT NONTRANSFERRABLE. No permit or license required by this sanitary code shall be transferable, nor shall any fees be refundable unless approved by the Authorized Representative.

1-3.2.4 PERMIT REVOCATION. All permits are subject to revocation for reason of noncompliance or misrepresentation. Procedure for appeal shall accompany notification of revocation.

1-3.2.5 STANDARD FEES. The Administrative Agency shall establish fees for all permits and licenses required by the code, and said fees shall be paid to the Authorized Representative. The Authorized representative shall not process any application for a permit or license until the required fee has been paid.

1-3.2.6 PERMIT DURATION. Construction of the wastewater system shall be completed within 12 months of the issuance of the permit. An extension may be granted by the Administrative Agency and an additional fee will be charged.

### 1-3.3 NOTICES, ORDERS, APPEALS

1-3.3.1 NOTICE OF VIOLATIONS. When the Authorized Representative determines that there has been a violation of any provision of this code, notice of such violation shall be issued to the person responsible. The notice shall: (1) be in writing; (2) include a statement why the notice is being issued, and the procedure to appeal; (3) allow a reasonable period of time for performance of any work required by the notice; and, (4) be properly served upon the last known address of the owner or agent. Such notice shall be deemed properly served when a copy has been sent by certified mail to the last known address of the owner or agent.

APPROVED

JAN 06 2011

1-3.3.2 APPEAL FOR HEARING. Any person aggrieved by any notice or order issued by the Authorized Representative under the provisions of this sanitary code may request, and shall be granted, a hearing on the matter before the Administrative Agency; provided such person shall file with the Administrative Agency, within ten (10) working days after the date of issuance of the notice or order, a written petition requesting a hearing and setting forth the grounds upon which the request was made. Except in the case of Emergency Orders as defined in Section 1-3.3.4, the filing of the request for a hearing shall operate as a stay of the notice of order. Upon receipt of such petition, the Administrative Agency shall set a time and place for such a hearing and shall give the petitioner written notice thereof at such hearing; the petitioner shall be given opportunity to show why such notice or order shall be modified or withdrawn. The hearing shall be commenced no later than ten (10) working days after the date on which the petition was filed provided, that upon request of the petitioner, the Administrative Agency may postpone the hearing for reasonable time beyond such ten-day period, when in the Agency's judgment the petitioner has submitted justifiable reason for such postponement.

1-3.3.3 REPORT OF HEARING. Within ten working days after such hearing, the Administrative Agency shall issue an order confirming, modifying, or withdrawing the notice or order, and shall notify the petitioner in the same manner as provided for in Section 1-3.3.1.

1-3.3.4 EMERGENCY ORDERS. Whenever the Authorized Representative finds that an emergency exists which requires immediate action to protect the public, the Authorized Representative may issue an order reciting the existence of such an emergency, and specifying action to be taken to meet the emergency. Such an order shall be effective immediately. Any person to whom such an order is directed shall comply immediately.

#### 1-3.4 RECORDS.

1-3.4.1 PERMIT APPLICATIONS. Applications for permits or licenses required by this code shall be filed with the Cloud County Clerk or Authorized Representative.

1-3.4.2 OFFICIAL ACTIONS. A written record of all official appeals action taken pertaining to the sanitary code shall be kept on file by the Administrative Agency in their official minutes.

1-3.4.3 PROCEEDING OF HEARINGS. The proceedings of all hearings, including findings, decisions, and a copy of every notice and order thereto shall be filed with the Administrative Agency. Hearings need not be transcribed, however; records should be kept in chronological order.



1-3.5 GENERAL PROVISIONS.

1-3.5.1 ENFORCEMENT PROCEDURE. It shall be the duty of the County Attorney to enforce the provisions of this code and other sanitary codes adopted by the county and hereby authorized to file appropriate actions for such enforcement, upon request of the Administrative Agency. Actions of injunction, mandamus, and quo warranto may be utilized for enforcement of these codes and shall be governed by the provisions of the Kansas Code of Civil Procedure.

1-3.5.2 PENALTIES. In addition to, and independently of, the enforcement procedures provided in Section 1-3.5.1, any violation of any provision of the sanitary code shall be deemed to be a misdemeanor, and upon conviction, punishable by a fine not to exceed two hundred dollars (\$200.00).

1-3.5.3 DISCLAIMER OF LIABILITY. This sanitary code adopted shall not be construed or interpreted as imposing upon the county, Authorized Representative, officials or its employees (1) any liability or responsibility for damages to any property, or (2) any warranty that any system, installation or portion thereof that is constructed under permits and inspections required by the sanitary code will function properly.

1-3.5.4 SEPARABILITY. If a clause sentence, paragraph or subsection of this code for any reason be adjudged by the court or competent jurisdiction to be unconstitutional and invalid, such judgment shall not affect, repeal or invalidate the remainder thereof, but shall be confined in its operation to the clause, sentence, paragraph, section or subsection found to be unconstitutional and invalid.

APPROVED:

JAN 05 2011

**SANITARY CODE**  
**CLOUD COUNTY, KANSAS**  
**CHAPTER 2**  
**ON-SITE WASTEWATER MANAGEMENT**

**SECTION 2-1.0 PURPOSE AND INTENT**

Sewage is a potential source of disease and water pollution, and a hazard to the health, safety and welfare of the public. It is the purpose of this chapter to provide minimum standards for the location, design, construction, maintenance and use of on-site wastewater systems, and the removal and disposal of materials from such facilities within the legal boundaries of Cloud County.

**SECTION 2-2.0 APPLICABILITY**

The provisions of this chapter shall apply to all unincorporated area located in Cloud County, Kansas.

**SECTION 2-3.0 DEFINITIONS**

- 2-3.1 BENEFICIAL USES means the use of water for any of the following purposes: agricultural water supply; aquatic life; domestic water supply; groundwater recharge; industrial water supply; recreation.
- 2-3.2 NEW CONSTRUCTION OF WASTEWATER SYSTEMS means any new construction initiated for the purpose of installing a domestic wastewater disposal system meeting the criteria referenced in Cloud County minimum design standards for onsite wastewater systems.
- 2-3.3 NUISANCE means conditions or activities on properties both public and private, which have or threaten to have a detrimental effect on the environment or the health of the public.
- 2-3.4 REPAIRS TO EXISTING WASTEWATER SYSTEMS means any modification to an existing domestic waste water disposal system.
- 2-3.5 PRIVATE WASTEWATER SYSTEM means any system which does not hold a Kansas Water Pollution Control Permit pursuant to K.S.A. 65-165. This includes wastewater disposal systems which function by soil absorption, evaporation, transpiration, holding tanks, or any combination of the above.

2-3.6 SANITARY PRIVY means a facility with a water-tight receptacle made of concrete or other material acceptable to the code administrator designed to receive, store and provide for periodic removal of non-water carried wastes from the human body. Material removed from the vault is transported and disposed at a publicly owned wastewater treatment facility or other means as approved by local authorities.

2-3.7 SANITARY SERVICE means the pumping out and/or removal of sewage, sludge, or human excreta from sanitary privies, vaults, septic tanks, or private wastewater disposal systems and the transportation of such material to a point of final disposal.

2-3.8 SANITARY SEWER LINE means a sealed or non-perforated line for the purpose of carrying sewage.

2-3.9 SEEPAGE PIT means a subsurface excavation, which is filled with rock or gravel and receives effluent from treatment devices.

2-3.10 SEWAGE means any substance that contains any of the waste product or excrementitious or other discharges from the bodies of human beings.

2-3.11 SUBDIVISION means any tract or parcel of land that is or has been subdivided into two or more lots for the purpose of sale or building development, whether immediate or future, including the streets, alleys, or other portions thereof intended to be dedicated for the public use, and any redivision of lands.

2-3.12 WASTEWATER SYSTEMS means any system along with attendant pipes and appurtenances designed and constructed to collect, store, treat, and dispose of domestic waste.

2-3.13 VAULTS/HOLDING TANKS means a watertight receptacle constructed of concrete or other material, designed to receive, store and provide for periodic removal of non-water carried wastes from the human body.

2-3.14 LAGOON OR WASTEWATER POND means a non discharging pond that receives only domestic waste.

2-3.15 CESSPOOL means a drywell that receives untreated sanitary wastes containing human excreta. A drywell is defined as a well completed above the water table so that its bottom and sides are typically dry except when receiving fluids.

#### **SECTION 2-4.0 PROHIBITED PRACTICES**

2-4.1 USE OF EXISTING WASTEWATER SYSTEMS. Existing wastewater systems prior to the adoption of this code are exempt of the requirements of this code unless the existing wastewater system poses a hazard to the public health as referred to in Section 2-4.2 a, c, and/or d.

2-4.2 USE OF NON-APPROVED PRIVATE SYSTEMS. No person shall sell, use, or cause to be used, any private wastewater system or privy constructed after adoption of this sanitary code, except under emergency conditions, until it has been inspected and approved by the Authorized Representative or if it:

- a. has been enjoined as a public health nuisance by a court of a competent jurisdiction, or
- b. fails to comply with the provisions of this sanitary code, and written notice thereof has been given by the Authorized Representative, or
- c. discharges into the water of the state as defined in K .S.A. 65-161 (a), or
- d. causes vector breeding, or produces offensive odors or any condition that is detrimental to health and comfort;
- e. discharges to a cesspool or seepage pit; or
- f. receives foundation drain, floor drain, surface water, or other non-domestic wastewater. Only domestic sewage shall be permitted to discharge to an approved on-site wastewater system.

2-4.3 USE OF PRIVATE WASTEWATER SYSTEMS WITHIN 400 FEET OF PUBLIC SEWER. A private wastewater system shall not be constructed less than 400 feet from an existing public sewer, unless the Authorized Representative finds connection to such a sewer is not feasible and that a private wastewater system, meeting the requirements of this code, can be constructed on that property.

2-4.4 LOCATION OF PRIVATE WASTEWATER SYSTEMS BELOW FULL/FLOOD POOL. No portion of a private wastewater system shall be located below the pool elevation of any reservoir or full poll elevation of any pond, lake or water supply reservoir.

2-4.5 LOCATION OF NEWLY CONSTRUCTED WASTEWATER SYSTEM WITHIN 100 FEET OF A WELL. A private wastewater system shall not be located less than 100 feet from a water well.

## **SECTION 2-5.0 REQUIREMENTS FOR PRIVATE WASTEWATER DISPOSAL SYSTEMS**

2-5.1 WAIVER/VARIANCE. The County Commissioner shall have the authority to grant a variance when reliable information is provided which can justify the exception and which will still protect the beneficial uses of the waters of the state and not create a nuisance. Before construction may begin on the onsite wastewater system, the variance must be filed and approved by the Authorized Representative to remain in compliance with KSA 28-5-9.

2-5.2 APPROVAL OF PLANS. After adoption of this code, no person shall construct any private wastewater system until the plans and specifications for such system have been approved by the Authorized Representative. Onsite wastewater systems shall be designed, constructed and operated in accordance with standards set forth in KDHE Bulletin 4-2 "Minimum Standards for Design and

APPROVED

JAN 06 2011

Kansas Department of  
Health and Environment

Construction of Onsite Wastewater Systems” published March 1997, as amended, by KDHE and Kansas State University Agricultural Experiment Station and Cooperative Extension Service. KDHE Bulletin 4-2 is hereby adopted by reference. Copies of KDHE Bulletin 4-2 can be obtained from the Authorized Representative upon request.

2-5.3 PERMIT. No person shall construct any private wastewater system until a permit has been issued by the Authorized Representative.

2-5.4 SUITABLE SITE. No site shall be approved if:

- a. Connection to an approved public wastewater system is feasible or the site violates the provisions of Section 2-4.0 of this code; or
- b. The site contains less than 3 acres of land exclusively of roads, streets or other public right-of-way or easements. Parcels and plats of land must meet the acreage requirements of the Sanitary Code in effect at the time the parcel or plat is deeded/filed, or
- c. The soil, topography and geology do not meet the requirements set forth in Section 2-6.0.

2-5.5 CONSTRUCTION APPROVAL. All newly constructed private wastewater systems developed after the effective date of this sanitary code must be inspected and approved by the Authorized Representative for compliance with the approved plans. No portion of the system shall be covered or made inaccessible to inspection prior to approval. The Authorized Representative must be notified at least one business day prior to the required inspection, except under emergency conditions. Construction completed in emergency conditions shall be reported to the Authorized Representative the following business day and any necessary permits obtained from the Authorized Representative.

2-5.6 PROPER MAINTENANCE AND APPROVAL. All private wastewater systems shall be maintained in good working condition. Whenever the Authorized Representative finds any private wastewater system in violation of this code, the owner and/or user shall be ordered to correct the condition. Existing private wastewater systems are exempt unless the system meets and one of the criteria set forth in Section 2-4.2.

2-5.7 PROPERTY SALE OR REFINANCE. No person shall sell or refinance any property which utilizes an onsite wastewater system without first having the Administrative Agency inspect and approve the onsite wastewater system. Failed systems must be brought into code compliance. The inspection shall consist of, but is not limited to, the following:

- a. The tank shall be pumped at time of inspection;
- b. The tank shall be checked for proper size, cracks, and presence of correct inlet and outlet baffles;
- c. Properly installed absorption field;
- d. Evidence of effluent discharge promoting or contributing to an environmental health hazard; and
- e. Wastewater stabilization pond (lagoon shall be checked for proper maintenance, fencing, gate, locks and other requirements as set forth by this code.

**SECTION 2-6.0 MINIMUM STANDARDS FOR SOIL TOPOGRAPHY AND GEOLOGY**

No private wastewater system shall be constructed on any lot of any size unless minimum standards are met for soil, topography, and geology as established in KDHE Bulletin 4-2 or current state standards.

**SECTION 2-7.0 REQUIREMENTS FOR WASTEWATER PONDS/ LAGOONS**

2-7.1 LAGOON CONSTRUCTION. All lagoons shall be constructed in accordance to Appendix A (attached).

2-7.2 LAGOON FENCING. Lagoons shall be fenced at time if construction and must meet or exceed the fencing standards stated in Appendix A (attached).

**SECTION 2-8.0 REQUIREMENTS FOR SANITARY PRIVIES**

2-8.1 APPROVAL OF PLANS. No person shall construct any sanitary privy until the plans and specifications for the proposed construction have been approved by the Authorized Representative.

2-8.2 APPROVAL OF CONSTRUCTION. No person shall sell, use, or make available for use, any newly constructed sanitary privy until the construction has been inspected and approved by the Authorized Representative for compliance with approved plans.

2-8.3 PROPER MAINTENANCE. No person shall use, or offer for use, any sanitary privy that is not maintained in a clean sanitary condition.

2-8.4 LOCATION OF A PRIVY WITHIN 100 FEET OF A WELL. No sanitary privy shall be installed less than 100 feet from an existing well.

**SECTION 2-9.0 REQUIREMENTS FOR SUBDIVISION DEVELOPMENT**

After adoption of this code no person shall develop any subdivision until the plan and specification for on-site wastewater management have been approved by the Authorized Representative and County Commissioners. Each building site shall be required to have a separate permit.

APPROVED

JAN 05 2011

**SANITARY CODE**  
**CLOUD COUNTY, KANSAS**  
**CHAPTER 3**  
**PRIVATE WATER SUPPLIES**

**SECTION 3-1.0 PURPOSE AND INTENT**

The provisions of this chapter are for the purpose of controlling the siting, maintenance, and use of all water supplies, other than public supplies and irrigated areas larger than 2 acres, used for human consumption, in Cloud County, KS, in order that public health will be protected and contamination and pollution of the water resources of the county will be prevented.

**SECTION 3-2.0 APPLICABILITY**

The provisions of this chapter shall apply to all unincorporated land located in Cloud County, Kansas.

**SECTION 3-3.0 DEFINITIONS**

3.3.1 CROSS-CONNECTION means no connection or arrangement shall be made between a potable water supply system and any equipment or device, through which it may be possible for used, unclean, polluted, and contaminated water or other substances, to enter into any part of such potable water system under any condition.

3.3.2 DOMESTIC USES means the use of water by any person or family unit or household for household purposes, or the watering of livestock, poultry, farm and domestic animals used in operating a farm, or the irrigation of lands not exceeding a total of two acres in area for the growing of gardens, orchards and lawns.

3-3.3 PRIVATE DOMESTIC WATER SUPPLY means all water supplies not meeting the definition of Public Water Supply, and used for Domestic Drinking Water purposes.

3-3.4 PUBLIC WATER SUPPLY WELL means a well that: (1) provides groundwater to the public for human consumption; and (2) has at least 10 service connections or serves an average of at least 25 individuals daily at least 60 days out of the year.

## **SECTION 3-4.0 REQUIREMENTS FOR PRIVATE DOMESTIC WATER SUPPLIES**

3-4.1 PERMIT. No person shall develop, use, sell or lease any newly constructed private domestic water supply until a permit has been obtained from the Authorized Representative.

3-4.2 APPROVED PLANS. No permit to develop a private domestic water supply subject to regulations of this code shall be issued until the plans have been approved by the Authorized Representative. References approved by KDHE shall be used as a guide by the Authorized Representative in reviewing and approving plans for private domestic water supply systems.

3-4.3 WAIVER/VARIANCE. The County Commissioners shall have the authority to grant exceptions when reliable information is provided which can justify the exception and which will still protect the beneficial uses of the waters of the state and not create a nuisance. All waivers/variances granted shall comply with provisions noted in K.A.R. 28-30-1 through 28-30-10 et. seq. as amended. If such waiver/variance doesn't comply with Article 30, a waiver/variance from KDHE must be maintained.

## **SECTION 3-5.0 MINIMUM STANDARDS FOR GROUNDWATER SUPPLIES**

3-5.1 LOCATION. All wells used as sources of water for water supplies shall be separated from the specified sources of pollution by distances equal to or greater than those shown on Table 1. Such distances may not be increased by the Administrative Agency to provide assurances that the well will not be contaminated.

3-5.2 CONSTRUCTION AND ENFORCEMENT. Well construction and the Enforcement of this section of the Cloud County Sanitary Code shall be regulated in accordance with K.A.R. 28-30-1 through 28-30-10 et seq.

## **SECTION 3-6.0 REQUIREMENTS FOR SUBDIVISION DEVELOPMENT**

3-6.1 SUBDIVISION DEVELOPMENT. After adoption of this code no person shall develop any subdivision until the plans specifications for water supply provision and/or protection have been approved by the Authorized Representative and the Cloud County Commissioners



**Table 1**

**MINIMUM SEPARATION DISTANCE BETWEEN PRIVATE DOMESTIC WATER SUPPLY WELLS AND SOURCES OF POLLUTION**

<u>Source of Pollution</u>	<u>Minimum Separation</u>	<u>Recommended Separation</u>
Subsurface absorption field for septic tank effluent	100 feet*	>100 feet*
Sanitary Privy	100 feet*	>100 feet*
Septic Tank	50 feet*	>100 feet*
Barnyards, stables, manure piles, animal pens, etc	50 feet*	>100 feet
Streams, lakes and ponds	50 feet*	>100 feet
Sewer lines <b>not</b> constructed of cast iron or other equally tight construction	50 feet*	>100 feet
Sewer lines constructed of cast iron or other equally tight construction	10 feet*	> 10 feet
Property Line	25 feet	> 25 feet

***\*As Required by K.A.R. 28-10-101***

APPROVED

JAN 05 2001

Kansas Department of  
Health and Environment

## APPENDIX A

# WASTEWATER LAGOON SYSTEMS

### Introduction:

The design criteria and construction standards contained herein are for the purpose of regulating and controlling the location, construction, maintenance and protection of wastewater lagoon systems used for private onsite domestic waste disposal. These requirements are intended to carry out the provisions set forth in Kansas Administrative Regulations (K.A.R.) 28-5-2 to 28-5-9 and the guidelines established by the Kansas Department of Health and Environment (KDHE) and the Cooperative Extension Service, Kansas Department of Agriculture, Kansas State University, Manhattan, Kansas. When properly designed, installed and maintained, odors from household lagoons are infrequent and visual impacts are minimal.

### Lagoon System:

A wastewater lagoon is a small non-discharging pond that receives only domestic waste. This pond has an average operational water depth of three to five feet (5'). All domestic wastewater must be included in the wastewater system including grey water (laundry wastewater and sink wastewater).

**Table 1: Minimum Required Distances from household Lagoon**

Property Line	50 feet
Private or Public Well	100 feet
Pond, perennial stream, or lake	50 feet
Public Water Line	25 feet
Dwelling from which wastewater originates	50 feet
Other buildings on same property	10 feet
Public Utility Lines	25 feet

Note: Distances measured from maximum water level.

### Lagoon Size:

The lagoon system will be sized and designed considering several factors provided on the permit application and soil evaluation. Table 2 shows wastewater pond designs.

**Table 2:**

<u>Design Size</u>	<u>Water Surface</u>	<u>Bottom</u>	<u>Top</u>	<u>Slope</u>
M35	35'	5'	47'	3: 1
M40	40'	10'	52'	3: 1
M45	45'	10'	59'	3.5: 1
M50	50'	15'	64'	3.5:1

APPROVED

Sewer Line to Lagoon:

The sewer line from the residence to the lagoon shall be a minimum of a four (4) inch diameter solid pipe. Schedule 40 or heavier is best, however, under high traffic areas, for example a driveway, Schedule 80 or heavier pipe must be used or the pipe needs to be double encased. All joints will have solvent welded joints.

Minimum slope of the line shall be 1/8 inch per foot (1 foot per 100 feet). The maximum slope shall not exceed 3/8 inch per foot or 3 feet per 100 feet. Sewer line slopes should not vary in order to avoid accumulation of solids in the pipe.

The trench bottom should be undisturbed soil and free of rocks or other material that could rupture the line. Backfill shall be compacted around the sides of the line at least 2 inches over the top of the line. The remainder of the trench shall be filled and mounded over trench to allow for settling.

At least two (2) cleanouts shall be provided. One clean out shall be located just outside the house (or inside) and the second shall be located near the lagoon. Additionally, a clean out is highly recommended every 100 feet or at every change in directions of the sewer line. Cleanouts may be a "T" or "Y" the same size as the sewer line.

The line should enter below the water surface and at least 18 inches above the bottom and should extend to near the center of the lagoon. The end should be anchored and supported. A splash pad of at least 2 feet X 2 feet must be placed under the pipe outlet location. A splash pad is concrete or flat rock pad and is essential to prevent the disruption of a lagoon seal.

Construction:

Any type of construction equipment may be used to build the wastewater pond. However, it is essential to have firm compaction of the lagoon area and berms. Construction shall not be done when the soil is muddy or excessively soft. Muddy soil is difficult to work and forms clods, which can prevent smoothing of the top of the dike. Excessively dry soil does not allow for proper soil compaction. When a backhoe is used for construction, additional compaction may be necessary for proper compaction.

Topsoil shall be removed from the pond and dike area before beginning the embankment construction and should be stockpiled for later use on the embankment.

Embankment slopes shall not be steeper than 3 feet (horizontal) to 1 foot (vertical).

The slopes shall ensure that the minimum design size of the pond maintains at least two feet of freeboard above the normal functional pond depth of five feet. The top of the slope berm shall have a minimum width of four feet. Surface water shall be diverted from the lagoon by constructing a diversion terrace around the upslope side of the lagoon (when required by the authorized representative).

The pond bottom and embankment surfaces shall be of uniform slope and free of rocks, slope debris, ridges and ruts that may interfere with mowing the embankment.

Topsoil should be replaced on embankment surface once the lagoon is completed. Perennial groundcover is necessary to reduce erosion. Groundcover shall be seeded as soon as it is feasible to plant the desired groundcover choice. A protective straw or hay cover mulch is encouraged to hold the soil and seed in place until the cover is established.

**FIGURE 1 depicts a typically constructed wastewater lagoon system.**

APPROVED

JAN 25 2013

Kansas Department of  
Health and Environment

Fencing Requirements:

The legal liability created by the wastewater lagoon lies entirely with the landowner or resident. To help protect the landowner and resident from liability exposure, the pond area must be fenced. The following fencing requirements are minimum standards. If these standards are not adequate to keep children or animals out of the lagoon area, the landowner is responsible for constructing and maintaining a more restrictive fence that will prevent access to the lagoon.

Fencing diagrams are shown in **FIGURES 2 through 5**. Fencing material must be a minimum of 4 feet tall and taller is highly recommended. Fence openings shall be no larger than 2"x4" or consist of combination cattle panels or woven wire. Types of acceptable fencing include chain link, welded wire, woven wire, horse panels or combination cattle panels. The combination cattle panels or woven wire must have smaller opening at the bottom or throughout the fence (2"x4"). When using the combination cattle type panels or woven wire at least one row of barb wire must be placed around the top. If livestock is accessible to the lagoon area all of the fence types should have barb wire and be placed at the bottom of the lagoon berm toe (outside). Without livestock, fence may be placed around the top of the lagoon berm, but cannot be any closer than 2 feet from the inside edge of the top of the embankment. Any type of fence posts may be used, but solid, sturdy corner posts are required or the corners must be securely anchored. Posts placed between the corners cannot be further than 10 ft apart. The fencing material must be flush to the ground at all points. Fence must be maintained properly at all times.

A hung gate of sufficient size (minimum of 4 ft. width and 4 ft. tall) must be located to accommodate the entrance of a mower. This gate must provide the same degree of resistance to entry as the fence. A locked gate is recommended to restrict unauthorized access.

Abandoned Wastewater Lagoons:

Any abandoned wastewater lagoon must have the fence removed, and completely filled in with soil. Abandoned wastewater lagoons are those are no longer required for its original intent. It is at the responsibility of the current landowner to eliminate the abandoned wastewater lagoon.

Maintenance:

In order for a lagoon to work properly, the landowner is responsible for keeping all vegetation shorter than 2 feet high. The landowner must take the means necessary to keep cattails, trees, and tall weeds out of the entire wastewater lagoon. Refer to K-State Research and Extension Water Quality Series Bulletin MF-2290 "Wastewater Pond Operation, Maintenance, and Repair" for detailed information on lagoon maintenance. Copies can be obtained through the local K-State Extension Office.

APPROVED

JAN 18 2011

**Figure 1: Domestic Lagoon System Construction**

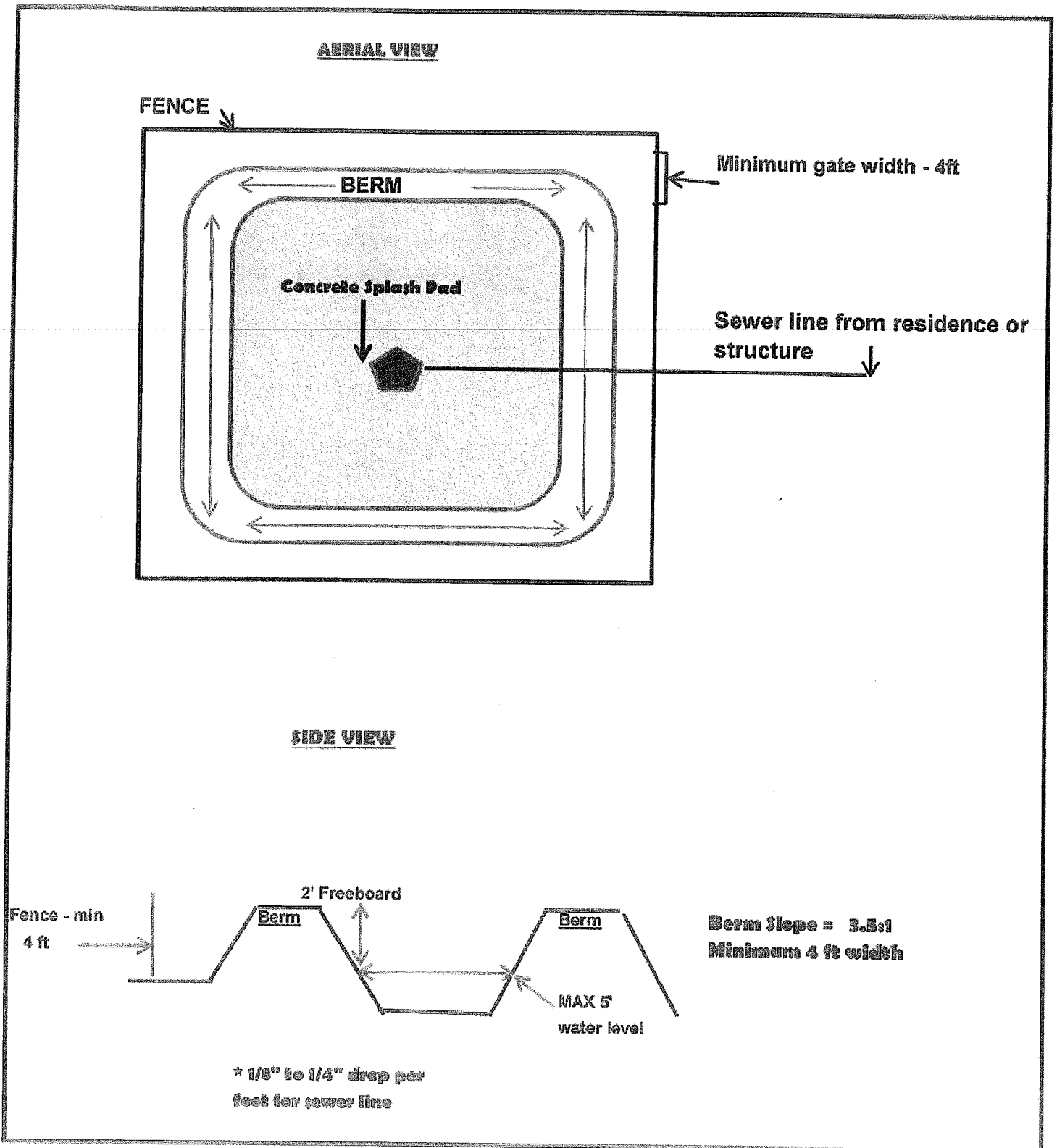

APPROVED

Figure 2: Lagoon Fencing

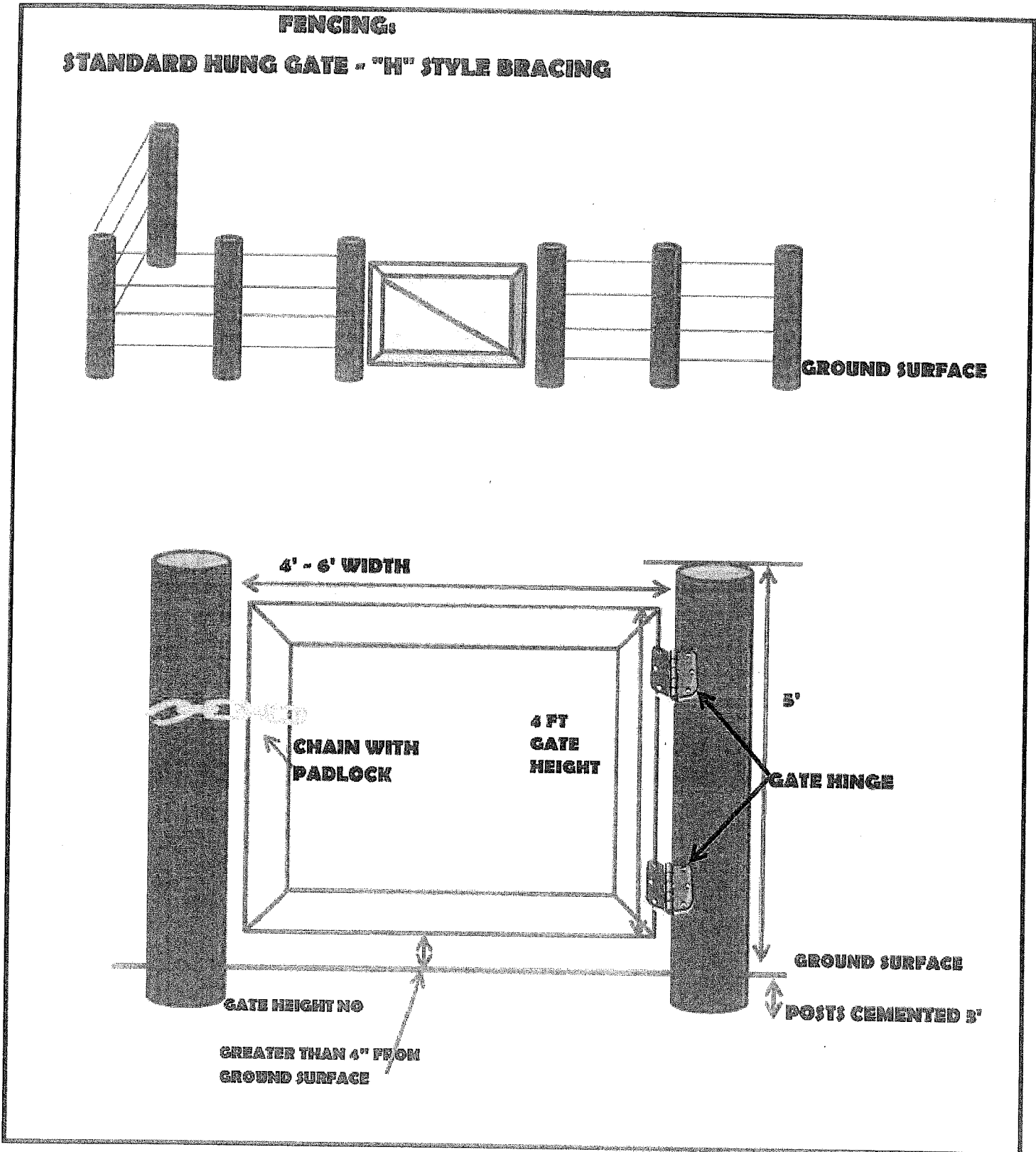

APPROVED

JAN 05 2011

Kansas Department of  
Health and Environment

Figure 3: Standard Bracing

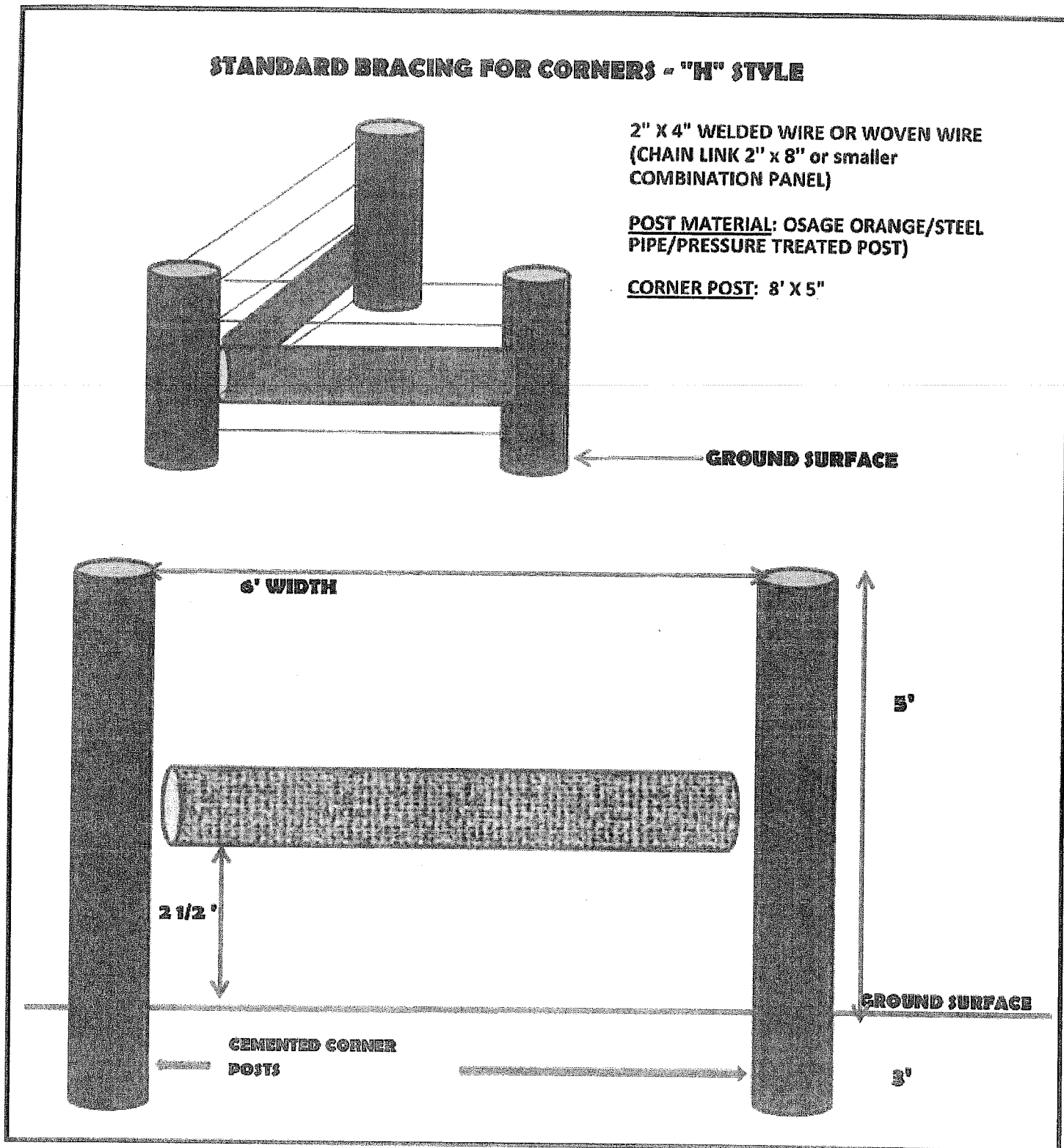

APPROVED

JAN 05 2011

Kansas Department of  
Health and Environment

**FIGURE 4: Standard Bracing Continued**

**STANDARD BRACING FOR CORNERS - "N" STYLE**

2" x 4" WELDED WIRE, WOVEN WIRE,  
CHAIN LINK OR 2" x 8" or smaller COMBINATION  
PANEL

POST MATERIAL: OSAGE ORANGE, STEEL PIPE  
OR PRESSURE TREATED POST

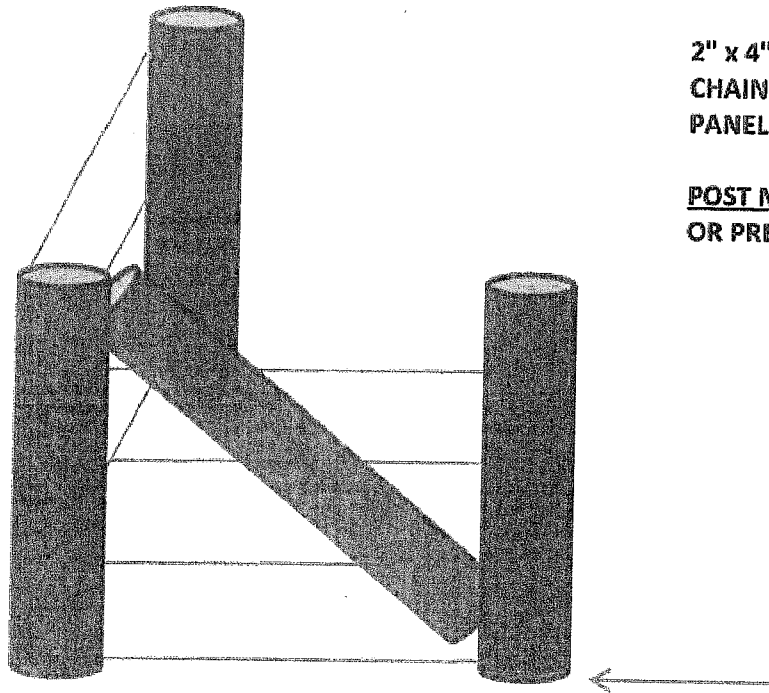

GROUND SURFACE

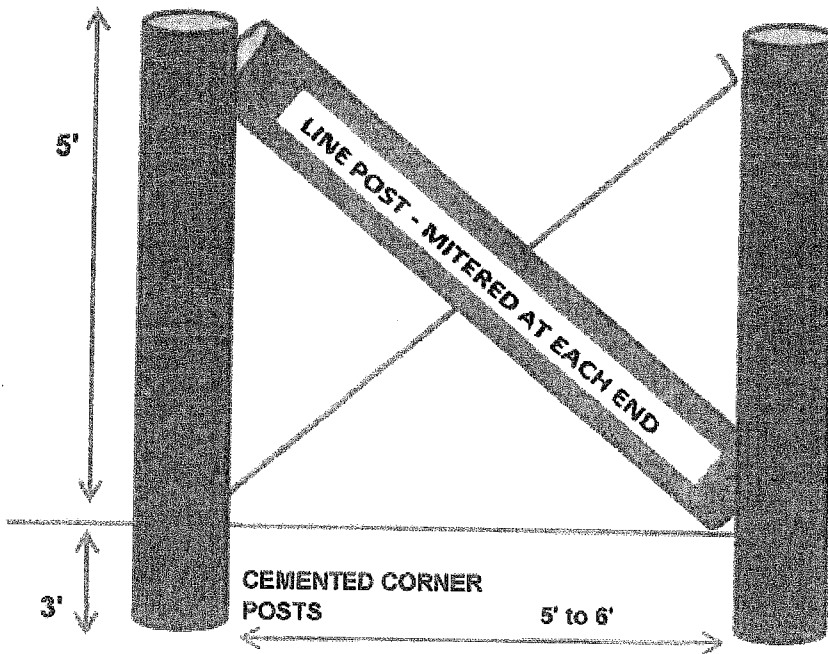

Anchor wire into posts  
(Twisted or barbed wire)

GROUND SURFACE

APPROVED

JAN 05 2011

Kansas Department of  
Health and Environment



**FIGURE 5**

**PROPER LOCATION FOR LAGOON FENCE**

**NO LIVESTOCK**

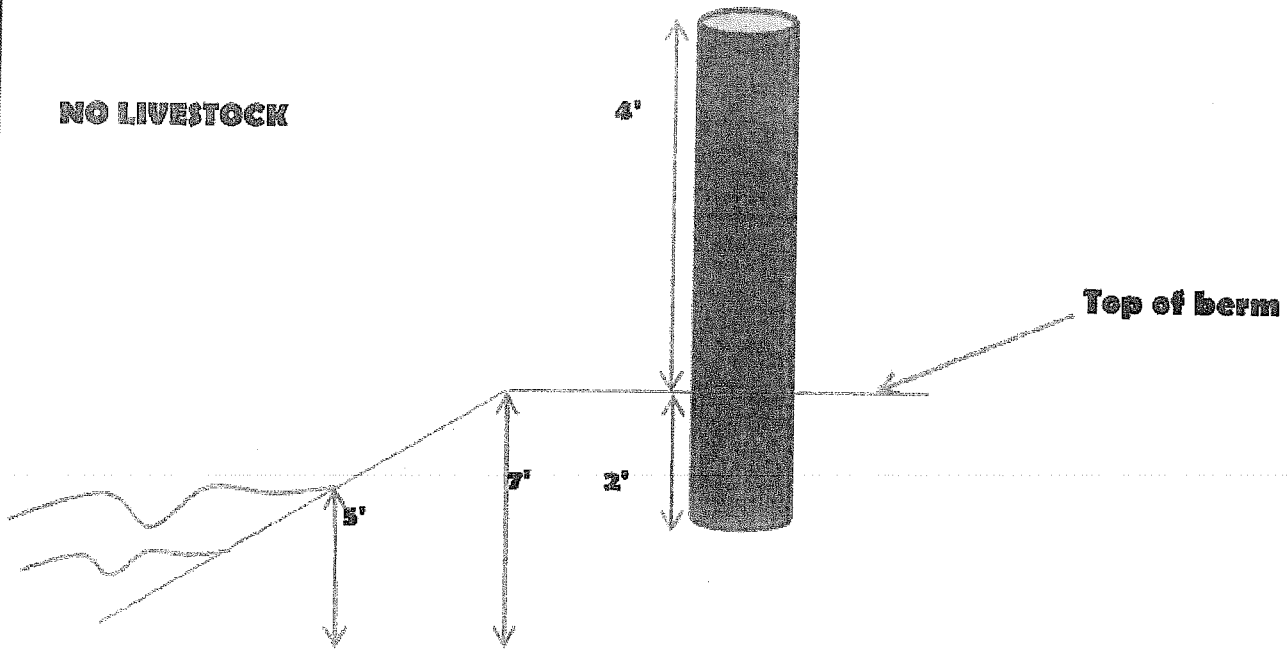

**WITH LIVESTOCK**

**Barbed wire strand across top**

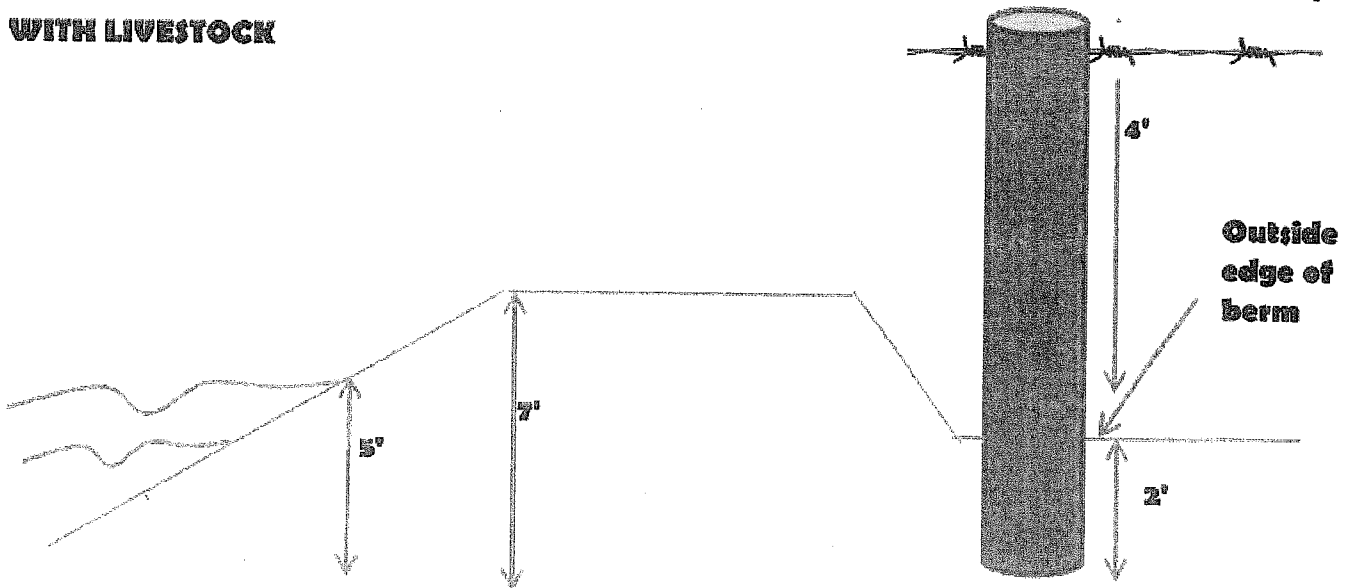

**APPROVED**

**JAN 05 2011**

**Kansas Department of  
Health and Environment**